

SmartAIR™
by AIR LIFT®

Kits 25415, 25430

Magnetic Height Sensor



INSTALLATION GUIDE

For maximum effectiveness and safety, please read these instructions completely before proceeding with installation.

Failure to read these instructions can result in an incorrect installation.



TABLE OF CONTENTS

Introduction	2
Important System Information	2
Notation Explanation	2
Installation Diagram	3
Hardware List	3
Installing the SmartAir System	4
Recommended Compressor Locations	4
Installing the Compressor and Deflate Solenoid	4
Attaching the Height Sensor	5
Attaching the Magnet and Mounting Bracket.	5
Installing the Electrical Components	6
Adjusting the System.	8
Checking the System.	8
Troubleshooting Guide	9
Troubleshooting Diagram	9
Troubleshooting Guide	9
Product Use	10
Frequently Asked Questions	10
Tuning the Air Pressure.	10
Guidelines for Adding Air.	11
Warranty and Returns Policy	11
Replacement Information	12
Contact Information	12

Introduction

The purpose of this publication is to assist with the installation, maintenance and troubleshooting of the SmartAir System.

It is important to read and understand the entire installation guide before beginning installation or performing any maintenance, service or repair. The information here includes a hardware list, tool list, step-by-step installation information, maintenance tips, safety information and a troubleshooting guide.

Air Lift Company reserves the right to make changes and improvements to its products and publications at any time. For the latest version of this manual, contact Air Lift Company at (800) 248-0892 or visit our website at www.airliftcompany.com.

IMPORTANT SYSTEM INFORMATION

The system is comprised of an Electronic Height Sensor (EHS), a bracket mounted magnet, solenoid valve, relay, air compressor, and an interconnecting wire harness. This system is combined with the previously installed air bags.

The EHS is mounted to the vehicle frame and the magnet is mounted to the axle or leaf spring. When load is added to the vehicle, the magnet rises above the EHS centerline (as the suspension is compressed). If the magnet maintains this position for a minimum of 25 seconds, the EHS will turn on the compressor, via the relay, adding air to the air bags. Air is added until the magnet is re-centered restoring the vehicle to its preset ride height.

When load is removed from the vehicle, the magnet falls below the EHS and energizes the solenoid valve. This allows the air to escape from the air bags until the magnet is re-centered and the reduction in load is accommodated.

An optional kneeling system can be purchased, which includes a dash mounted rocker switch. This system works to manually exhaust air from the bags when a lower vehicle is needed while parking.

NOTATION EXPLANATION

Hazard notations appear in various locations in this publication. Information which is highlighted by one of these notations must be observed to help minimize risk of personal injury or possible improper installation which may render the vehicle unsafe. Notes are used to help emphasize areas of procedural importance and provide helpful suggestions. The following definitions explain the use of these notations as they appear throughout this guide.

DANGER

INDICATES IMMEDIATE HAZARDS WHICH WILL RESULT IN SEVERE PERSONAL INJURY OR DEATH.

WARNING

INDICATES HAZARDS OR UNSAFE PRACTICES WHICH COULD RESULT IN SEVERE PERSONAL INJURY OR DEATH.

CAUTION

INDICATES HAZARDS OR UNSAFE PRACTICES WHICH COULD RESULT IN DAMAGE TO THE MACHINE OR MINOR PERSONAL INJURY.

NOTE

Indicates a procedure, practice or hint which is important to highlight.

Installation Diagram

HARDWARE LIST

Item	Part #	Description	Qty
A	24050	Electronic Magnetic Height Sensor	1
B	16092	Compressor	1
C	26238	Exhaust Solenoid Assembly	1
D	26687	Harness	1
E	20220	1/4" Air Line	20'

Item	Part #	Description	Qty
F	10966	Magnet	1
G	10967	Magnet Mounting Bracket	1
H	10466	8" Black Zip Tie	12
I	21838	1/4" x 1/4" x 1/4" Union Tee	4
J	17173	1/4" x 3/4" Self-Tapping Screw	3
K	17185	#8 - 32 x 3/8" Washer Head Screw	2
L	18417	#8 Lock Washer	2
M	18600	#10 - 24 x 1.25" Socket Cap Screw	1
N	18498	3/16 - 24 Nyloc Nut	1
O	10583	3/8" x 3.5" x 4.5" U-bolt	1
P	01426	Clamp Bar	1
Q	18435	3/8" - 16 Nyloc Nut	2
R	18444	3/8" Flat Washer	2
S	17132	#8 - 18 x 1/2" Self-Tapping Screw	1
T	26833	Pressure Release Valve Assembly	1

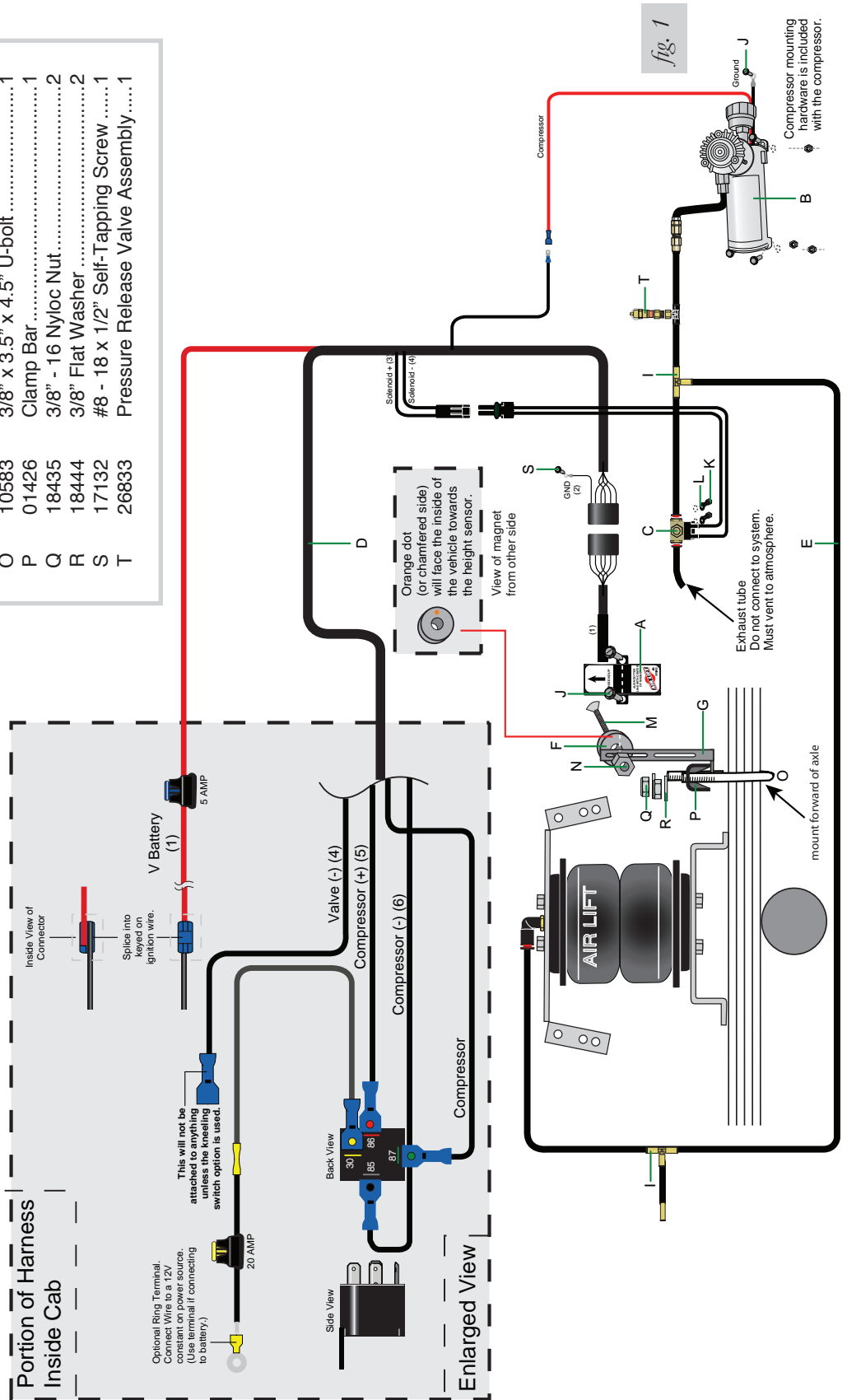

Installing the SmartAir System

RECOMMENDED COMPRESSOR LOCATIONS

Important

LOCATE COMPRESSOR IN DRY, PROTECTED AREA ON VEHICLE.
DIRECT SPLASH OR EXCESSIVE MOISTURE CAN DAMAGE
THE COMPRESSOR AND CAUSE SYSTEM FAILURE.

Disclaimer: If you choose to mount the compressor outside the vehicle please keep in mind the compressor body must be shielded from direct splash and the intake should be snorkeled inside the vehicle. If the compressor does not include a remote mount air filter or if mounting the compressor outside the vehicle, make sure to orient the compressor intake filter so that all moisture can easily drain.

Please also remember...

- To avoid high heat environments
- To avoid mounting the compressor under the hood.
- To check to be sure the compressor harness #2 will reach the compressor and connect to harness #1.
- The compressor can be mounted in any position — vertical, upside down, sideways, etc. (please refer to the instruction manual).

INSTALLING THE COMPRESSOR AND DEFLATE SOLENOID

1. Attach the filter to the fitting on the end of the compressor.
2. Select a rigid mounting location on your vehicle's frame or crossmember that shields the compressor from the elements and heat sources (fig. 2). Refer to chart below for step-by-step instructions.

NOTE

The compressor and deflate solenoid must be mounted within reach of the wires when the wiring harness is plugged in.

CAUTION

MOUNT THE COMPRESSOR AND DEFLATE SOLENOID AT LEAST 6" FROM ANY HEAT SOURCES. DO NOT MOUNT THE COMPRESSOR OR THE MANIFOLD IN THE ENGINE COMPARTMENT.

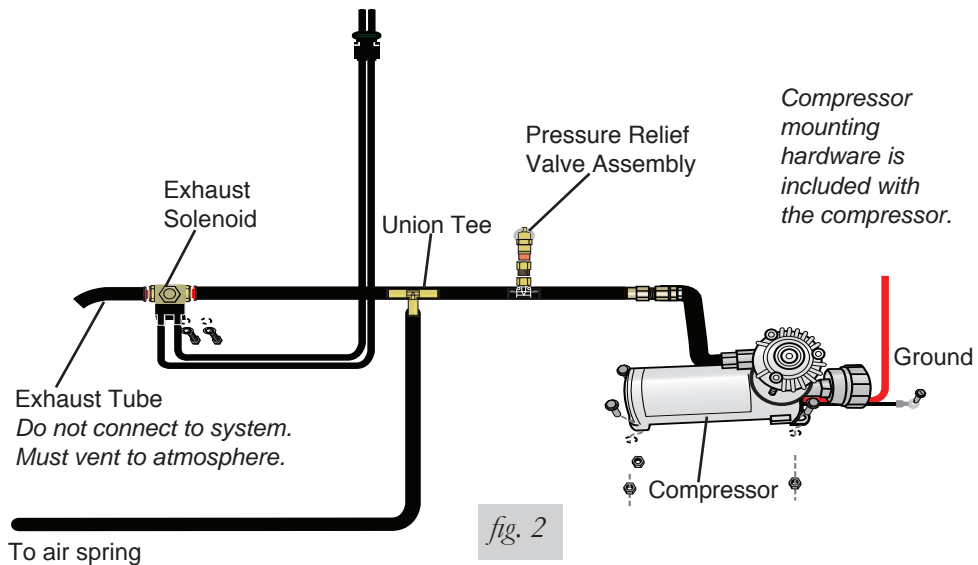

	1	2	3
Compressor	Centerpunch and drill four 1/4" diameter holes using the compressor feet as a template.	Attach using four supplied screws.	Fasten using four supplied nuts.
Solenoid	Centerpunch and drill two 3/16" diameter holes using the template on the back of the manual?	Attach using two supplied lock washers and bolts.	

- Cut a length of air line and remove the compression nut in the end of the leader hose and slip it over the air line. Insert the barb on the leader hose into the air line, seating it completely against the leader hose fitting. Thread the nut onto the fitting and tighten. Connect the other end of the air line to one of the push-to-connect fittings on the tee of the pressure relief valve assembly (fig. 2).
- Cut another length of air line and attach one end to the open push-to-connect fitting on the tee of the assembly and the other end of the air line to the solenoid valve.

NOTE

It may be necessary to stabilize the pressure relief valve assembly. If so, use a tie strap and attach it to the frame rail or a crossmember.

- Attach the compressor and deflate solenoid to the frame rail or crossmember using fig. 2 as a guide.
- Mount the solenoid as close to the compressor or air spring as possible (fig. 2). Use the template on the back of the manual for mounting the solenoid.

CAUTION

MOUNT THE COMPRESSOR AND DEFLATE SOLENOID AT LEAST 6" FROM ANY HEAT SOURCES. DO NOT MOUNT THE COMPRESSOR OR THE MANIFOLD IN THE ENGINE COMPARTMENT.

ATTACHING THE HEIGHT SENSOR

- Choose a mounting location along the frame rail for the height sensor.

NOTE

Preferably mount the height sensor forward of the axle.

- Using the provided screws and nyloc nuts, attach the height sensor to the chosen frame-mounting location (fig. 3).

CAUTION

STAY CLEAR OF ANYTHING THAT MAY HIT THE HEIGHT SENSOR WHILE THE SUSPENSION TRAVELS IN JOUNCE AND COMPRESSION.

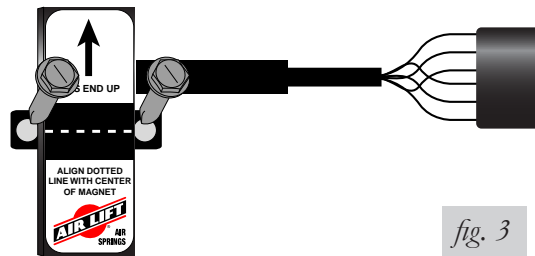

fig. 3

ATTACHING THE MAGNET AND MOUNTING BRACKET

CAUTION

THE MAGNET HAS A STRONG PULL. USE CARE WHEN HANDLING AS NOT TO PINCH FINGERS OR SKIN.

- Place the supplied u-bolt around the leaf springs near the previously mounted height sensor (fig. 4 and fig. 5).

- Using the figures below as a guide, choose the best mounting method for your vehicle.

NOTE

When choosing the mounting method, keep in mind that the center of the magnet must align with the height sensor when the vehicle is at ride height. The magnet and the height sensor must be between 1" - 1½" apart.

- Attach the bracket to the u-bolt using the chosen mounting method per fig. 4 and fig. 5.
- Loosely attach the magnet to the bracket using the supplied bolt and nyloc nut.

NOTE

There is a small orange dot (or chamfered side) on the magnet that will face the inside of the vehicle towards the height sensor.

- Align the center of the magnet with the dotted line on the height sensor. Once the magnet is in line, securely tighten the hardware.

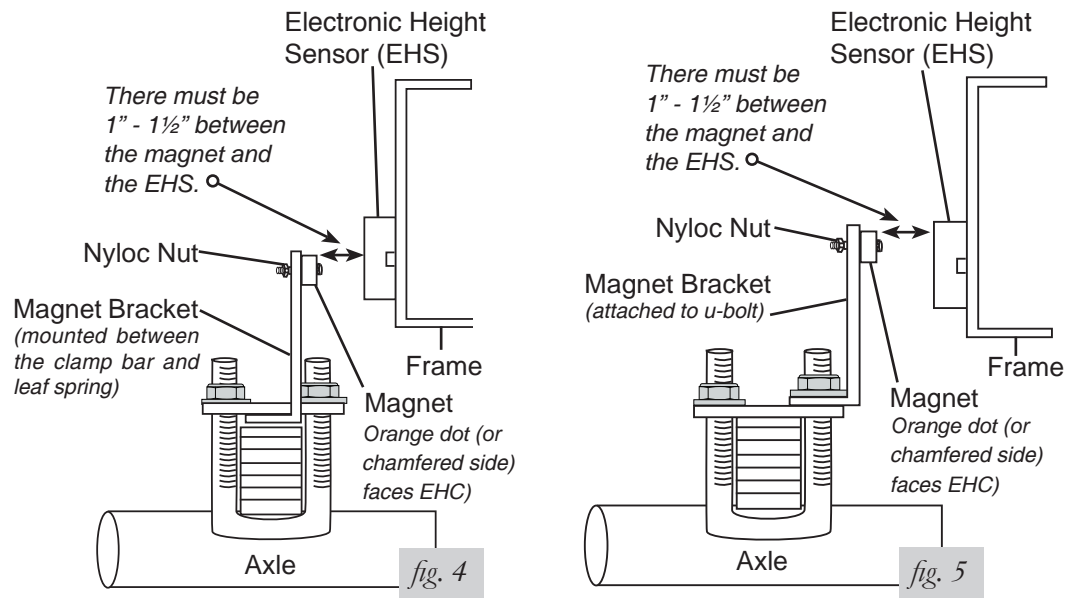

INSTALLING THE ELECTRICAL COMPONENTS

- Run the harness from the cab to the solenoid/compressor location.

NOTE

It may be necessary to drill a hole so that the harness can easily pass through from the cab to the vehicle frame. Place a grommet or silicone sealant around any holes that the harness passes through to protect it from abrasive surfaces.

- Connect single terminal connectors to connect the black compressor wire to the relay wire (fig. 6).
- Connect the double terminal connector from the solenoid to the double terminal connector relay wires (fig. 6).
- Splice the red wire with the 5 AMP fuse that is connected to the back of the relay to a keyed on ignition wire (fig. 7).
- Using a butt connector, attach the 12 gauge wire from the terminal 30 on the back of the relay to one end of the 20 amp fuse holder (fig. 8).
- If choosing to use the ring terminal, attach it to the other end of the fuse wire (fig. 8).
- Choose an appropriate 12+ volt source on the vehicle.

NOTE

A direct connection to the battery is suggested.

- Attach the terminal end of the ground wire to a clean section of the framerail using the provided self-tapping screw (fig. 9).

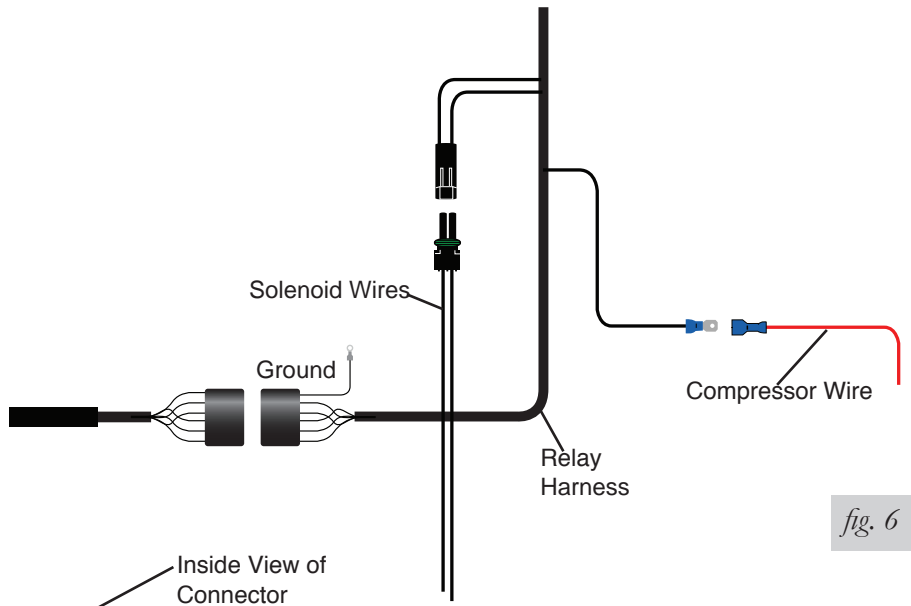

fig. 6

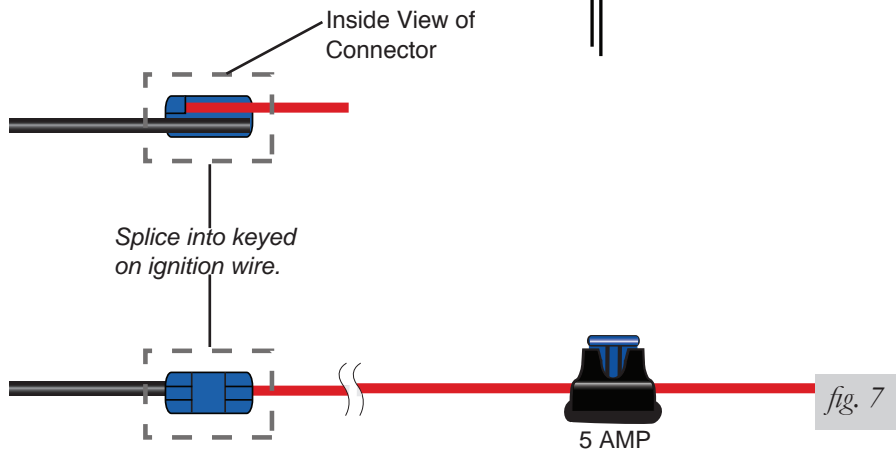

fig. 7

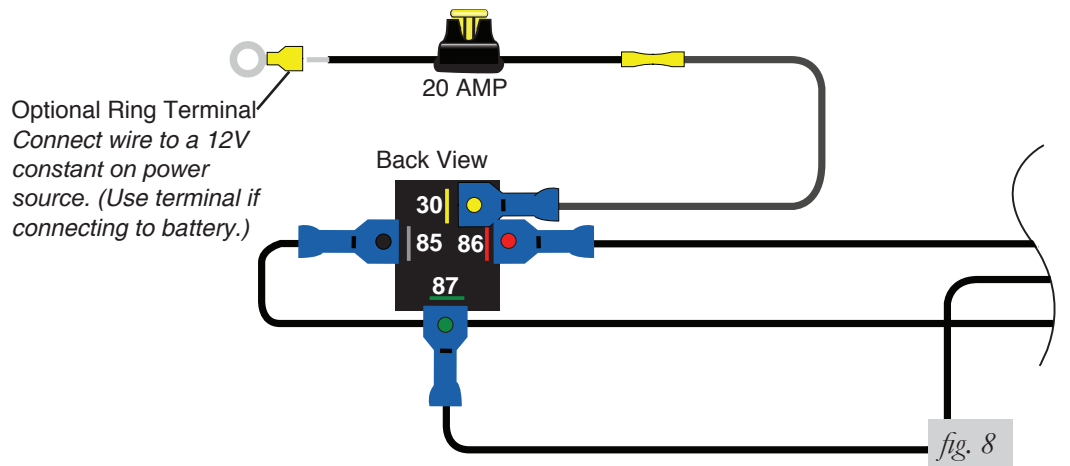

fig. 8

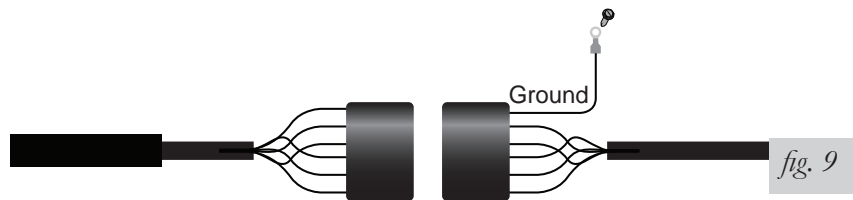

fig. 9

ADJUSTING THE SYSTEM

1. Make sure that the distance between the face of the magnet and the electronic height sensor (EHS) is between 1" to 1-1/2".
2. As stated in figure one, the orange dot (or chamfered side) on the magnet must be facing the EHS.

CAUTION

THIS MAGNET IS VERY STRONG. IT IS POSSIBLE FOR THE MAGNET TO PINCH SKIN AND SMALL BODY PARTS BETWEEN ANOTHER MAGNET OR METAL OBJECT. CARE SHOULD BE TAKEN WHEN HANDLING THE MAGNET.

3. You can adjust the suspension by moving the magnet up or down in the slotted mounting bracket. It is recommended that the magnet be set a half inch below the center of the EHS to start. Take a reference measurement from ground to the rear bumper or the wheel well.
4. Turn the ignition key to the accessory or on position.

NOTE

You should hear the system cycle (deflate and inflate) every time the key is turned on in an unladen condition. This is a system maintenance function to maintain the minimum PSI in the rear air springs. If the vehicle is laden, the key-on function will be disabled by the EHS.

The preferred method of adjusting the system would be to laden the vehicle with a load, then adjust the magnet so that the suspension obtains the height you desire. Usually a good starting point would be to set the vehicle (using the magnet) at a level ride height, or one inch below the stock curb height unladen (using the measurement taken in step 3).

NOTE

There is a 25 second delay in the system. Once the magnet is set in position and no movement is detected by the EHS, it will take 25 seconds for the compressor, or the deflate solenoid, to turn on and level the vehicle by inflating, or deflating, the air springs in the suspension.

Once the desired ride height is obtained, tighten the magnet mounting screw snug, do not over tighten.

CHECKING THE SYSTEM

1. Inspect all air line connections with a solution of 1/5 dish soap to 4/5 water. Should a leak be detected in a push-lock-fitting, reinstall the air line to the fitting. Make sure air line is cut off squarely and that the air line is completely pushed into the fitting.
2. If the compressor or the solenoid fails to function, check the 20 AMP fuse and ground connection. Repair and replace as necessary.

Troubleshooting Guide

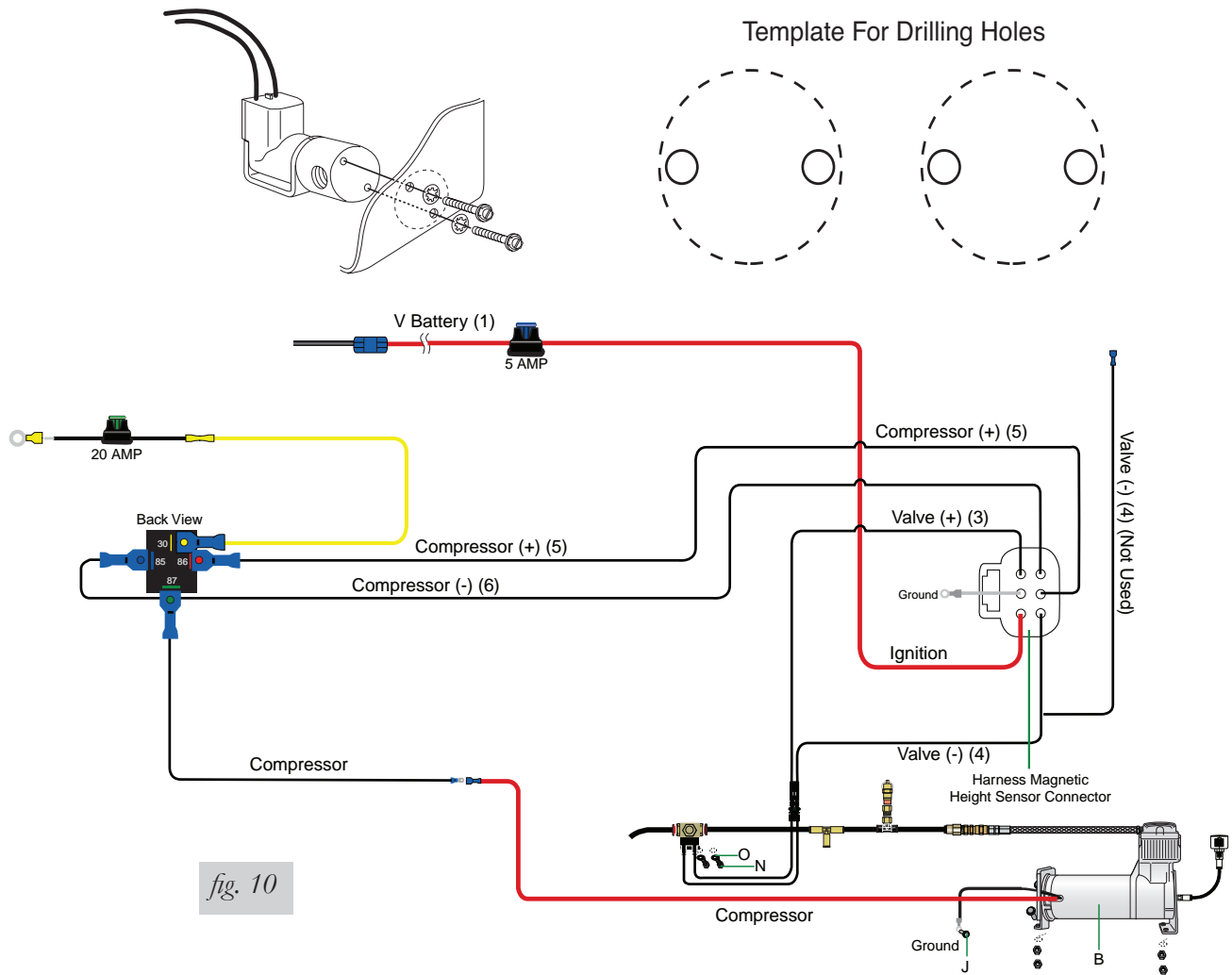

fig. 10

PROBLEM	CAUSE	SOLUTION
<i>The system has a 25 second delay before the compressor and solenoid will function.</i>		
Compressor doesn't run.	Blown fuse, bad ground, poor connection, bad compressor or ECU.	Check fuses, grounds and connections. Ground terminal 85 at relay to see if compressor runs. Unplug compressor and test.
Solenoid doesn't work.	Blown fuse, bad connections, bad solenoid or ECU.	Check fuse, connection, unplug solenoid and jumper power and ground to check operation.
Compressor runs all the time.	Leak in system, bad relay or ECU.	Locate leak, replace relay or check ECU.
Vehicle does not maintain ride height.	Bad/leaking solenoid or bad ECU.	Unplug solenoid and test by jumping power and ground.
Nothing happens when the vehicle is started.	Blown fuse, poor ground or connection.	Check fuses, connections and grounds.
	Bad ECU.	Test individual components to verify and ground terminal 85 to test -compressor and harness.
	Magnet may not be properly aligned, may be backward or may be improper distance from ECU.	Check magnet alignment, distance, and insure orange dot (or chamfered side) is facing ECU.

Product Use

FREQUENTLY ASKED QUESTIONS

Q. Will installing air springs increase the weight ratings of a vehicle?

No. Adding air springs will not change the weight ratings (GAWR, GCWR and/or GVWR) of a vehicle. Exceeding the GVWR is dangerous and voids the Air Lift warranty.

Q. Is it necessary to keep air in the air springs at all times and how much pressure will they need?

The minimum air pressure should be maintained at all times. The minimum air pressure keeps the air spring in shape, ensuring that it will move throughout its travel without rubbing or wearing on itself.

Q. Is it necessary to add a compressor system to the air springs?

No. Air pressure can be adjusted with any type of compressor as long as it can produce sufficient pressure to service the springs. Even a bicycle tire pump can be used, but it's a lot of work.

Q. How long should air springs last?

If the air springs are properly installed and maintained they can last indefinitely.

Q. Will raising the vehicle on a hoist for service work damage the air springs?

No. The vehicle can be lifted on a hoist for short-term service work such as tire rotation or oil changes. However, if the vehicle will be on the hoist for a prolonged period of time, support the axle with jack stands in order to take the tension off of the air springs.

TUNING THE AIR PRESSURE

Pressure determination comes down to three things — level vehicle, ride comfort, and stability.

1. Level vehicle

If the vehicle's headlights are shining into the trees or the vehicle is leaning to one side, then it is not level (fig. 11). Raise the air pressure to correct either of these problems and level the vehicle.

2. Ride comfort

If the vehicle has a rough and harsh ride it may be due to either too much pressure or not enough (fig. 12). Try different pressures to determine the best ride comfort.

3. Stability

Stability translates into safety and should be the priority, meaning the driver may need to sacrifice a perfectly level and comfortable ride. Stability issues include roll control, bounce, dive during braking and sponginess (fig. 13). Tuning out these problems usually requires an increase in pressure.



Bad headlight aim

fig. 11



Rough ride

fig. 12



Sway and body roll

fig. 13

GUIDELINES FOR ADDING AIR

1. Start with the vehicle level or slightly above.
2. When in doubt, always add air.
3. For motorhomes, start with 50-100 PSI in the rear because it can be safely assumed that it is heavily loaded.
4. If the front of the vehicle dives while braking, increase the pressure in the front air bags, if equipped.
5. If it is ever suspected that the air bags have bottomed out, increase the pressure (fig. 14).
6. Adjust the pressure up and down to find the best ride.
7. If the vehicle rocks and rolls, adjust the air pressure to reduce movement.
8. It may be necessary to maintain different pressures on each side of the vehicle. Loads such as water, fuel, and appliances will cause the vehicle to be heavier on one side (fig. 15). As much as a 50 PSI difference is not uncommon.



Bottoming out

fig. 14

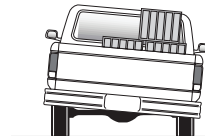

Unlevel

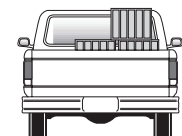

Level

fig. 15

Warranty and Returns Policy

Air Lift Company warrants its products, for the time periods listed below, to the original retail purchaser against manufacturing defects when used on catalog-listed applications on cars, vans, light trucks and motorhomes under normal operating conditions for as long as Air Lift manufactures the product. The warranty does not apply to products that have been improperly applied, improperly installed, used in racing or off-road applications, used for commercial purposes, or which have not been maintained in accordance with installation instructions furnished with all products. The consumer will be responsible for removing (labor charges) the defective product from the vehicle and returning it, transportation costs prepaid, to the dealer from which it was purchased or to Air Lift Company for verification.

Air Lift will repair or replace, at its option, defective products or components. A minimum \$10.00 shipping and handling charge will apply to all warranty claims. Before returning any defective product, you must call Air Lift at (800) 248-0892 in the U.S. and Canada (elsewhere, (517) 322-2144) for a Returned Materials Authorization (RMA) number. Returns to Air Lift can be sent to: Air Lift Company • 2727 Snow Road • Lansing, MI • 48917.

Product failures resulting from abnormal use or misuse are excluded from this warranty. The loss of use of the product, loss of time, inconvenience, commercial loss or consequential damages is not covered. The consumer is responsible for installation/reinstallation (labor charges) of the product. Air Lift Company reserves the right to change the design of any product without assuming any obligation to modify any product previously manufactured.

This warranty gives you specific legal rights and you may also have other rights that vary from state-to-state. Some states do not allow limitations on how long an implied warranty lasts or allow the exclusion or limitation of incidental or consequential damages. The above limitation or exclusion may not apply to you. There are no warranties, expressed or implied including any implied warranties of merchantability and fitness, which extend beyond this warranty period. There are no warranties that extend beyond the description on the face hereof. Seller disclaims the implied warranty of merchantability. (Dated proof of purchase required.)

Air Lift 1000.....	Lifetime Limited	LoadController/Dual.....	2 Year Limited
RideControl.....	Lifetime Limited	Load Controller (I)	2 Year Limited
LoadLifter 5000*.....	Lifetime Limited	Load Controller (II)	2 Year Limited
SlamAir	Lifetime Limited	SmartAir	2 Year Limited
AirCell.....	Lifetime Limited	Wireless AIR.....	2 Year Limited
Air Lift Performance**.....	1 Year Limited	WirelessONE.....	2 Year Limited
LoadController/Single.....	2 Year Limited	Other Accessories.....	2 Year Limited

**formerly SuperDuty*

***formerly LifeStyle & Performance and EasyStreet*

Replacement Information

If you need replacement parts, contact the local dealer or call Air Lift customer service at (800) 248-0892. Most parts are immediately available and can be shipped the same day.

Contact Air Lift Company customer service at (800) 248-0892 first if:

- Parts are missing from the kit.
- Need technical assistance on installation or operation.
- Broken or defective parts in the kit.
- Wrong parts in the kit.
- Have a warranty claim or question.

Contact the retailer where the kit was purchased:

- If it is necessary to return or exchange the kit for any reason.
- If there is a problem with shipping if shipped from the retailer.
- If there is a problem with the price.

Contact Information

If you have any questions, comments or need technical assistance contact our customer service department by calling (800) 248-0892, Monday through Friday, 8 a.m. to 8 p.m. Eastern Time. For calls from outside the USA or Canada, our local number is (517) 322-2144.

For inquiries by mail, our address is PO Box 80167, Lansing, MI 48908-0167. Our shipping address for returns is 2727 Snow Road, Lansing, MI 48917.

You may also contact us anytime by e-mail at sales@airliftcompany.com or on the web at www.airliftcompany.com.

Notes

Need Help?

Contact our customer service department by calling (800) 248-0892, ext. 1, Monday through Friday, 8 a.m. to 8 p.m. Eastern Time. For calls from outside the USA or Canada, our local number is (517) 322-2144.



Thank you for purchasing Air Lift products — the professional installer's choice!

Air Lift Company • 2727 Snow Road • Lansing, MI 48917 or PO Box 80167 • Lansing, MI 48908-0167
Toll Free (800) 248-0892 • Local (517) 322-2144 • Fax (517) 322-0240 • www.airliftcompany.com

Printed in
the USA