

RideCONTROL™
by AIR LIFT®

by AIR LIFT®

Kit 59516



INSTALLATION GUIDE

For maximum effectiveness and safety, please read these instructions completely before proceeding with installation.

Failure to read these instructions can result in an incorrect installation.

TABLE OF CONTENTS

Introduction	2
Important Safety Notice	2
Notation Explanation	2
Installation Diagram	3
Hardware List	4
Tools List	4
Getting Started.	4
Important Notes	4
Normal Ride Height	5
Assembling the Installation Tool	5
Installing the RideControl System.	5
Attaching the Assembly	5
Installing the Air Lines	7
Aligning the Air Spring	8
Checking for Leaks	8
Fixing Leaks	8
Maintenance and Servicing	9
Minimum and Maximum Pressure	9
Maintenance Guidelines	9
Warranty and Return Policy	9
Replacement Information	10
Contact Information	10

Introduction

The purpose of this publication is to assist with the installation and maintenance RideControl air spring kit. The air springs used in RideControl kits are designed and manufactured like a tire. The air springs have layers of rubber and cords that control the bag's growth and funnel it into one direction. The bags do not require a coil spring for control. RideControl kits utilize a sleeve style air bag that provides up to 2,000 pounds of load-leveling support. Each sleeve is rated at a maximum of 100 p.s.i.

It is important to read and understand the entire installation guide before beginning installation or performing any maintenance, service or repair. The information here includes a hardware list, tool list, step-by-step installation information, maintenance tips and safety information.

Air Lift Company reserves the right to make changes and improvements to its products and publications at any time. Contact Air Lift Company at (800) 248-0892 or visit us online at www.airliftcompany.com for the latest version of this manual.

IMPORTANT SAFETY NOTICE

The installation of this kit does not alter the Gross Vehicle Weight Rating (GVWR) or payload of the vehicle. Check your vehicle's owner's manual and do not exceed the maximum load listed for your vehicle.

Gross Vehicle Weight Rating: The maximum allowable weight of the fully loaded vehicle (including passengers and cargo). This number — along with other weight limits, as well as tire, rim size and inflation pressure data — is shown on the vehicle's Safety Compliance Certification Label.

Payload: The combined, maximum allowable weight of cargo and passengers that the truck is designed to carry. Payload is GVWR minus the Base Curb Weight.

NOTATION EXPLANATION

Hazard notations appear in various locations in this publication. Information which is highlighted by one of these notations must be observed to help minimize risk of personal injury or possible improper installation which may render the vehicle unsafe. Notes are used to help emphasize areas of procedural importance and provide helpful suggestions. The following definitions explain the use of these notations as they appear throughout this guide.

DANGER

INDICATES IMMEDIATE HAZARDS WHICH WILL RESULT IN SEVERE PERSONAL INJURY OR DEATH.

WARNING

INDICATES HAZARDS OR UNSAFE PRACTICES WHICH COULD RESULT IN SEVERE PERSONAL INJURY OR DEATH.

CAUTION

INDICATES HAZARDS OR UNSAFE PRACTICES WHICH COULD RESULT IN DAMAGE TO THE MACHINE OR MINOR PERSONAL INJURY.

NOTE

Indicates a procedure, practice or hint which is important to highlight.

Installation Diagram

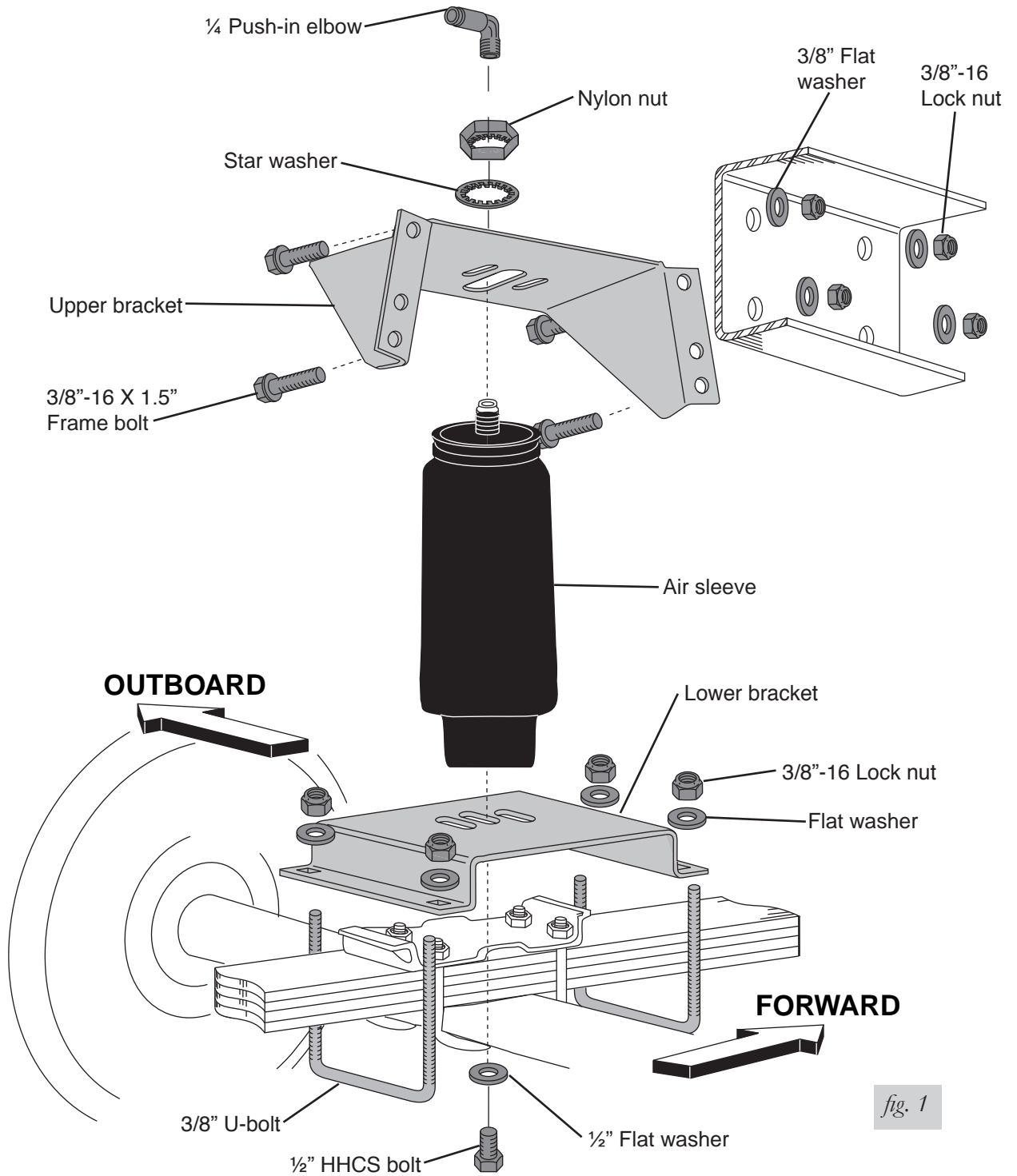

fig. 1

HARDWARE LIST

Item	Part #	Description.....Qty	Item	Part #	Description.....Qty
A	58688	Air spring.....2	K	18444	3/8" Flat washer8
B	07475	Upper bracket2	L	18454	Jam nut1
C	03102	Lower bracket2	M	18450	Lock washer.....2
D	10591	Installation tool1	N	17159	3/8"-16 x 1.5 Frame bolt.....8
E	33606	1/4" Elbow2	O	20086	Air line assembly.....1
F	10583	3/8" U-bolt4	P	21230	Valve cap2
G	18414	1/2" Flat washer2	Q	18405	5/16" Flat washer2
H	17124	Hex head cap screw bolt.....2	R	21234	Rubber washer.....2
I	01525	Spacer.....4	S	18411	Star washer.....2
J	18435	3/8"-16 Nyloc nut.....16	T	21233	5/16" Hex nut4



Missing or damaged parts? Call Air Lift customer service at (800) 248-0892 for a replacement part.

TOOLS LIST

Description..... Qty	Description..... Qty
Hoist or floor jacks 1	Ratchet with 9/16", metric, & 1/2" deep well sockets 1
Safety stands..... 2	3/8" and 5/16" drill bits (very sharp)..... 2
Safety glasses 1	Heavy duty drill 1
Torque wrench..... 1	Hose cutter, razor blade, or sharp knife 1
5/16" open-end or box wrench..... 1	Air compressor or compressed air source..... 1
7/16" open-end or box wrench..... 1	Spray bottle with dish soap/water solution 1
9/16" open-end or box wrench..... 1	
Crescent wrench..... 1	

Getting Started

IMPORTANT NOTES

1. Your vehicle may be equipped with a rear brake proportioning valve. Any type of load assist suspension product could effect brake performance. We recommend that you check with your dealer before installing this type of product. If your vehicle does not have a proportioning valve or is equipped with an anti-lock brake system, no adjustment or modification is required.
2. Before proceeding with installation, measure the opening from the frame rail to the brake drum or the tire, which ever is closest to frame. The measurement must be a minimum of 7 inches (fig. 2). If spacing is good, remove rear wheels and support frame with safety stands.

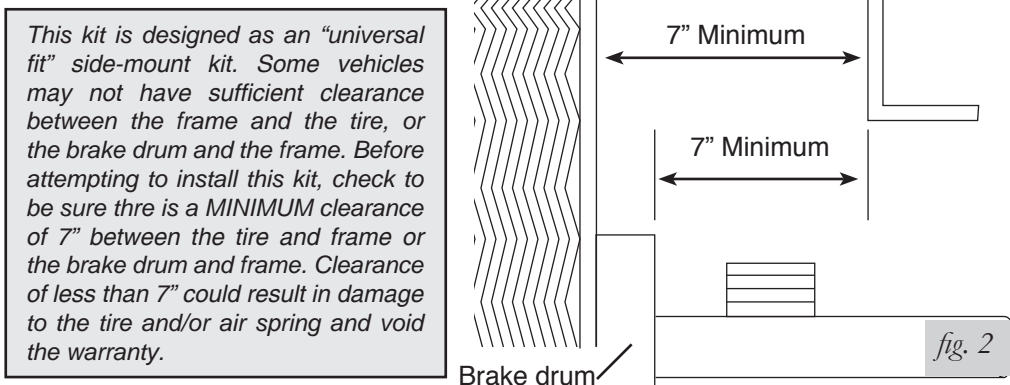

NORMAL RIDE HEIGHT

This is defined as the distance between the bottom edge of the wheel well to the center point of the wheel with the vehicle in an “as delivered condition” (without a load, i.e. tool box, camper, etc.) measurements should be taken before beginning the installation. The distance from the bottom edge of the wheel well to the center point of the wheel should be recorded. All of our kits are designed to be installed and operated at normal ride height.

1. Raise axle or lower frame until leaf spring is in the normal ride height (no load) position.
2. Check the distance between the center of the hub and the bottom edge of the wheel well to ensure that it is at the normal ride height measurement taken above. If not, raise the frame or lower the axle as necessary to restore the original distance. The vehicle must be at normal ride height before installing the upper bracket.

ASSEMBLING THE INSTALLATION TOOL

1. Assemble the upper and lower bracket to the alignment tool. This tool is designed to help you properly install the kit for correct height and alignment. The range of adjustment to attain the correct mounted height is determined by the upper threaded section of the tool. The kit may be mounted anywhere in that range (fig. 3).
2. Place the upper bracket “legs down” onto the threaded end of the tool resting on the bottom pal nut. Then thread a second pal nut (flange up) onto the tool to hold the bracket in place. Leave loose for later adjustment. (fig. 3).
3. Use the ½” x 7/8” hex head bolt and flat washer to attach the lower bracket to the bottom of the installation tool with the open edge of the lower bracket toward the legs of the upper bracket. Leave loose enough to adjust in and out (fig. 3).

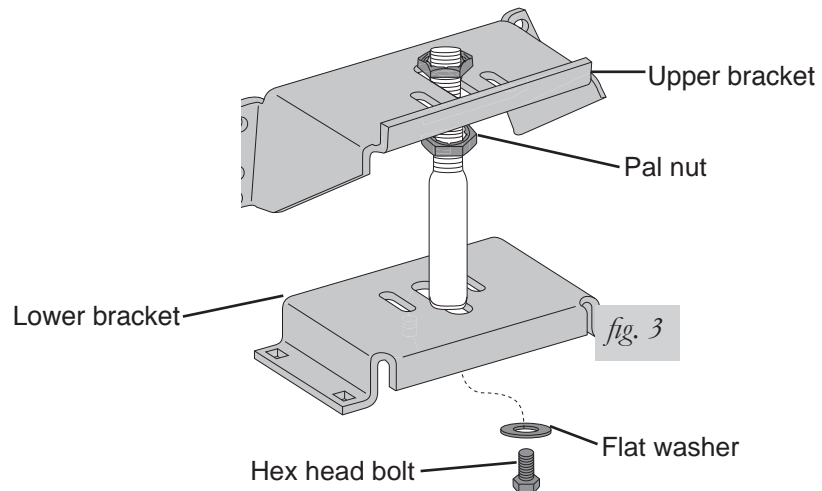

Installing the RideControl System

ATTACHING THE ASSEMBLY

1. Set the assembly on the leaf spring centered over the axle and attach the lower bracket as shown in fig. 4 using the u-bolts, flat washers and lock nuts. Tighten nuts to 20 ft/lbs.
2. Using the slot in the lower bracket, push the upper bracket against the frame rail. Use the pal nuts on the threaded portion of the installation tool to adjust the upper bracket so that the flanges of the upper bracket are flat against the frame rail and at least four mounting holes are on the flat middle section of the frame rail. Do not drill any holes on the upper or lower radiused edge of the frame rail. You must also allow at least 1.5” above the upper bracket for air fitting clearance. The brackets can be mounted anywhere within the threaded range of the installation tool.

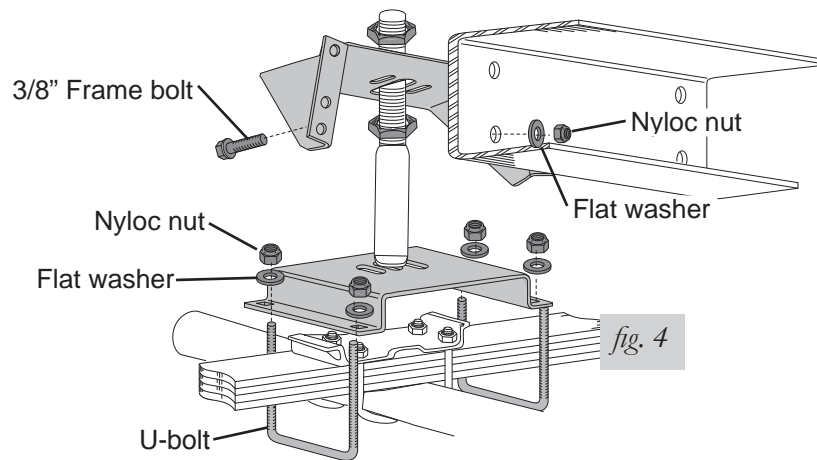
**NOTE**

The frame has an indented area directly over the axle. Normally the upper bracket will span this indented area. If the flange of the upper bracket falls onto or just inside the radiused edges of the indent, it is ok. Drill and fasten tight to that rounded surface (fig. 5).

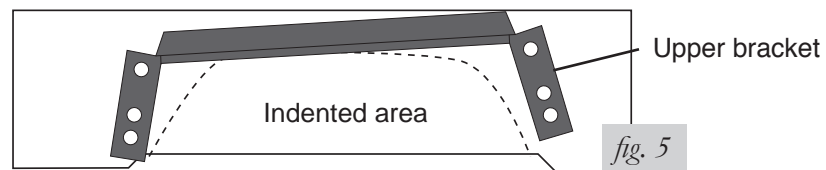
**CAUTION**

DO NOT DRILL HOLES INTO THE FRAME UNTIL ANY HYDRAULIC LINES, GAS LINE AND ELECTRICAL WIRES HAVE BEEN MOVED ASIDE ON BOTH SIDES OF FRAME RAIL.

- Using the upper bracket as a template, centerpunch one of the lower mounting holes and drill a 3/8" hole through the frame. Install one of the mounting bolts and LOOSELY attach the oversized flat washer and locknut. Now centerpunch and drill a 3/8" hole at the other lower mounting hole location. DO NOT insert the mounting bolt at this time (fig. 4).
- You can now remove the installation tool by removing the upper pal nut, loosening and removing the tool from the bottom bolt (leave in place), and slightly rotating the upper bracket to give you enough room to completely remove the tool.
- Rotate the upper bracket back to the original location and install the frame bolt, oversized flat washer and locknut through the second hole you drilled. Now tighten both of the installed fasteners to 20 ft/lbs. Drill the other two holes and install the fasteners. Torque to 20 ft/lbs (fig. 6).

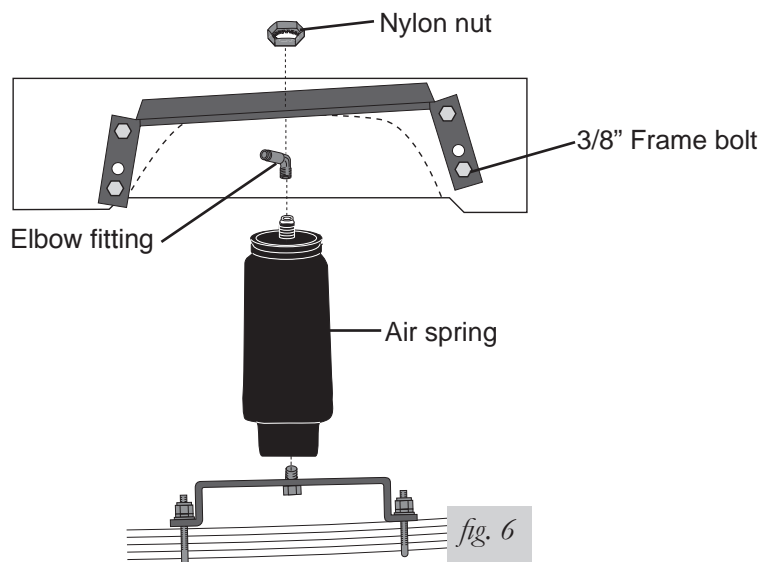

6. Install the elbow fitting into air port of the air sleeve. The fitting is precoated with thread sealant. Tighten finger tight plus two turns. Use a 7/16" open end wrench being careful to tighten on the metal hex nut only. Do not overtighten (fig. 6).
7. Guide upper thread post/fitting through the center mounting hole in the upper bracket (fig. 6).
8. Attach the air spring to the lower bracket by carefully hand turning the air spring onto the lower mounting bolt. LEAVE LOOSE for later adjustment (fig. 6).
9. Now install the nylon nut onto the upper thread post of the air spring. LEAVE LOOSE for final adjustment (fig. 6).
10. Repeat procedure for other side of vehicle.

INSTALLING THE AIR LINES

1. Choose a convenient location for mounting the inflation valves. Popular locations for the inflation valve are:
 - a. The wheel well flanges.
 - b. License plate recess in bumper.
 - c. Under the gas cap access door.
 - d. Through license plate itself.

NOTE

What ever the chosen location is, make sure there is enough clearance around the inflation valves for an air chuck.

2. Drill a 5/16" hole to install the inflation valves.
3. Cut the air line assembly in two equal lengths.

CAUTION

WHEN CUTTING OR TRIMMING THE AIR LINE, USE A HOSE CUTTER, A RAZOR BLADE OR A SHARP KNIFE. A CLEAN, SQUARE CUT WILL ENSURE AGAINST LEAKS. DO NOT USE WIRE CUTTERS OR SCISSORS TO CUT THE AIR LINE. THESE TOOLS MAY FLATTEN OR CRIMP THE AIR LINE, CAUSING IT TO LEAK AROUND THE O-RING SEAL INSIDE THE ELBOW FITTING (FIG. 7)

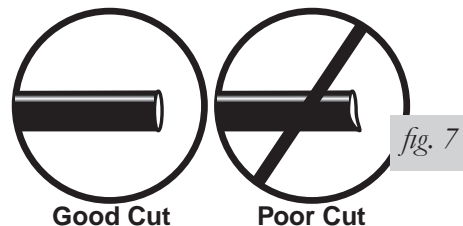

4. Place a 5/16" nut and a star washer on the air valve. Leave enough of the inflation valve in front of the nut to extend through the hole and have room for the rubber washer, flat washer, and 5/16" nut and cap. There should be enough valve exposed after installation - approximately 1/2" - to easily apply a pressure gauge or an air chuck (fig. 8).

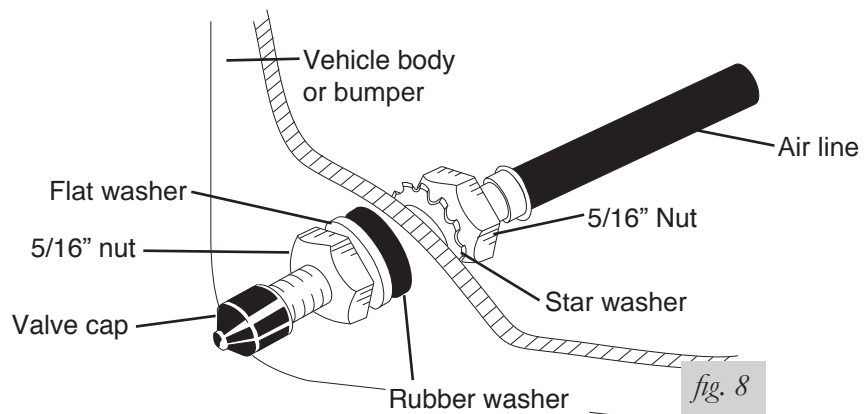

5. Push the inflation valve through the hole and use the rubber washer, flat washer, and another 5/16" nut. Tighten the nuts to secure the assembly in place (fig. 8).
6. Route the air line along the frame to the air fitting on the air spring (fig. 9). Keep AT LEAST 6" of clearance between the air line and heat sources, such as the exhaust pipes, muffler, or catalytic converter. Avoid sharp bends and edges. Use the plastic tie straps (BB) to secure the air line to fixed, non-moving points along the chassis. Be sure that the tie straps are tight, but do not pinch the air line. Leave at least 2" of slack to allow for any movement that might pull on the air line.

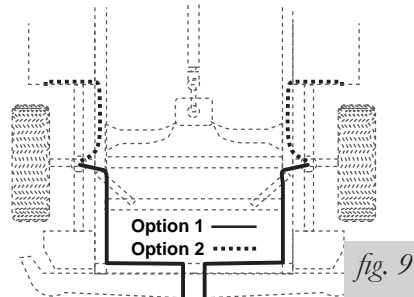

7. Cut off air line leaving approximately 12" of extra air line. A clean square cut will ensure against leaks (see fig. 7). Insert the air line into the air fitting. This is a push to connect fitting. Simply push the air line into the 90° swivel fitting until it bottoms out (9/16" of air line should be in the fitting).

ALIGNING THE AIR SPRING

1. **VERY IMPORTANT** - With the top and bottom still loose, inflate the air springs to approximately 10 p.s.i. Use the slots in the brackets to correctly align the air spring between the upper and lower brackets. This can be accomplished by tapping it inboard or outboard for proper alignment. There should be symmetrical cushion of air around the base of the air spring when correctly positioned.

CHECKING FOR LEAKS

1. Inflate the air spring to 30 p.s.i. and spray all connections and the inflation valves with a solution of 1/5 liquid dish soap and 4/5 water to check for leaks. Spot leaks easily by looking for bubbles in the soapy water.
2. After the test, deflate the springs to the minimum pressure required to restore the normal ride height, no less than 5 p.s.i.
3. Check the air pressure again after 24 hours. A 2-4 p.s.i. loss after initial installation is normal. Retest for leaks if the loss is more than 5 lbs.

FIXING LEAKS

1. If there is a problem with the swivel fitting:
 - a. Check the air line connection by deflating the spring and removing the line by pulling the collar against the fitting and pulling firmly on the air line. Trim 1" off the end of the air line. Be sure the cut is clean and square (see fig. 7). Reinsert the air line into the push-to-connect fitting.
 - b. Check the threaded connection by tightening the swivel fitting another 1/2 turn. If it still leaks, deflate the air spring, remove the fitting, and re-coat the threads with thread sealant. Reinstall by hand tightening as much as possible, then use a wrench for an additional two turns.
2. If there is a problem with the inflation valve, then:
 - a. Check the valve core by tightening it with a valve core tool.
 - b. Check the air line connection by removing the air line from the barbed type fitting.

 **CAUTION**

DO NOT CUT THE AIR LINE COMPLETELY OFF AS THIS WILL NICK THE BARB AND RENDER THE FITTING USELESS.

- If the preceding steps have not resolved the problem, call Air Lift customer service at (800) 248-0892 for assistance.

Maintenance and Servicing

Minimum Air Pressure	Maximum Air Pressure
5 p.s.i.	100 p.s.i.
FAILURE TO MAINTAIN CORRECT MINIMUM PRESSURE (OR PRESSURE PROPORTIONAL TO LOAD), BOTTOMING OUT, OVER-EXTENSION OR RUBBING AGAINST ANOTHER COMPONENT WILL VOID THE WARRANTY.	

MAINTENANCE GUIDELINES

NOTE

By following these steps, vehicle owners will obtain the longest life and best results from their air spring.

- Check the air pressure weekly.
- Always maintain normal ride height. Never inflate beyond 100 p.s.i.
- If you develop an air leak in the system, use a soapy water solution to check all air line connections and the inflation valve core, before deflating and removing the spring.
- When increasing load, always adjust the air pressure to maintain normal ride height. Increase or decrease pressure from the system as necessary to attain normal ride height for optimal ride and handling. Remember that loads carried behind the axle (including tongue loads) require more leveling force (pressure) than those carried directly over the axle.

 **CAUTION**

FOR YOUR SAFETY AND TO PREVENT DAMAGE TO YOUR VEHICLE, DO NOT EXCEED MAXIMUM GROSS VEHICLE WEIGHT RATING (GVWR), AS INDICATED BY THE VEHICLE MANUFACTURER. ALTHOUGH YOUR AIR SPRINGS ARE RATED AT A MAXIMUM INFLATION PRESSURE OF 100 P.S.I., THE AIR PRESSURE ACTUALLY NEEDED IS DEPENDENT ON YOUR LOAD AND GVWR.

- Always add air to the springs in small quantities, checking the pressure frequently. Sleeves require less air volume than a tire and inflate quickly.
- Should it become necessary to raise the vehicle by the frame, make sure the system is at a minimum pressure (5 p.s.i.) to reduce tension on the suspension/brake components. Use of on-board leveling systems do not require deflation or disconnection.

Warranty and Returns Policy

Air Lift Company warrants its products, for the time periods listed below, to the original retail purchaser against manufacturing defects when used on catalog-listed applications on cars, vans, light trucks and motorhomes under normal operating conditions for as long as Air Lift manufactures the product. The warranty does not apply to products that have been improperly applied, improperly installed, used in racing or off-road applications, used for commercial purposes, or which have not been maintained in accordance with installation instructions furnished with all products. The consumer will be responsible for removing (labor charges) the defective product from the vehicle and returning it, transportation costs prepaid, to the dealer from which it was purchased or to Air Lift Company for verification.

Air Lift will repair or replace, at its option, defective products or components. A minimum \$10.00 shipping and handling charge will apply to all warranty claims. Before returning any defective product, you must call Air Lift at (800) 248-0892 in the U.S. and Canada (elsewhere, (517) 322-2144) for a Returned Materials Authorization (RMA) number. Returns to Air Lift can be sent to: Air Lift Company • 2727 Snow Road • Lansing, MI • 48917.

Product failures resulting from abnormal use or misuse are excluded from this warranty. The loss of use of the product, loss of time, inconvenience, commercial loss or consequential damages is not covered. The consumer is responsible for installation/reinstallation (labor charges) of the product. Air Lift Company reserves the right to change the design of any product without assuming any obligation to modify any product previously manufactured.

This warranty gives you specific legal rights and you may also have other rights that vary from state-to-state. Some states do not allow limitations on how long an implied warranty lasts or allow the exclusion or limitation of incidental or consequential damages. The above limitation or exclusion may not apply to you. There are no warranties, expressed or implied including any implied warranties of merchantability and fitness, which extend beyond this warranty period. There are no warranties that extend beyond the description on the face hereof. Seller disclaims the implied warranty of merchantability. (Dated proof of purchase required.)

Air Lift 1000	Lifetime Limited	LoadController/Dual	2 Year Limited
RideControl	Lifetime Limited	Load Controller (I)	2 Year Limited
LoadLifter 5000*	Lifetime Limited	Load Controller (II)	2 Year Limited
SlamAir	Lifetime Limited	SmartAir	2 Year Limited
AirCell	Lifetime Limited	Wireless AIR	2 Year Limited
Air Lift Performance**	1 Year Limited	WirelessONE	2 Year Limited
LoadController/Single	2 Year Limited	Other Accessories	2 Year Limited

**formerly SuperDuty*

***formerly LifeSTYLE & Performance*

Replacement Information

If you need replacement parts, contact the local dealer or call Air Lift customer service at (800) 248-0892. Most parts are immediately available and can be shipped the same day.

Contact Air Lift Company customer service at (800) 248-0892, first if:

- Parts are missing from the kit.
- Need technical assistance on installation or operation.
- Broken or defective parts in the kit.
- Wrong parts in the kit.
- Have a warranty claim or question.

Contact the retailer where the kit was purchased:

- If it is necessary to return or exchange the kit for any reason.
- If there is a problem with shipping if shipped from the retailer.
- If there is a problem with the price.

Contact Information

If you have any questions, comments or need technical assistance contact our customer service department by calling (800) 248-0892, Monday through Friday, 8 a.m. to 7 p.m. Eastern Time. For calls from outside the USA or Canada, our local number is (517) 322-2144.

For inquiries by mail, our address is PO Box 80167, Lansing, MI 48908-0167. Our shipping address for returns is 2727 Snow Road, Lansing, MI 48917.

You may also contact us anytime by e-mail at sales@airliftcompany.com or on the web at www.airliftcompany.com.

Need Help?

Contact our customer service department by calling (800) 248-0892, Monday through Friday, 8 a.m. to 7 p.m. Eastern Time. For calls from outside the USA or Canada, our local number is (517) 322-2144.

**Register your warranty online at
www.airliftcompany.com/warranty**



Thank you for purchasing Air Lift products — the professional installer's choice!

Air Lift Company • 2727 Snow Road • Lansing, MI 48917 or PO Box 80167 • Lansing, MI 48908-0167
Toll Free (800) 248-0892 • Local (517) 322-2144 • Fax (517) 322-0240 • www.airliftcompany.com

Printed in
the USA