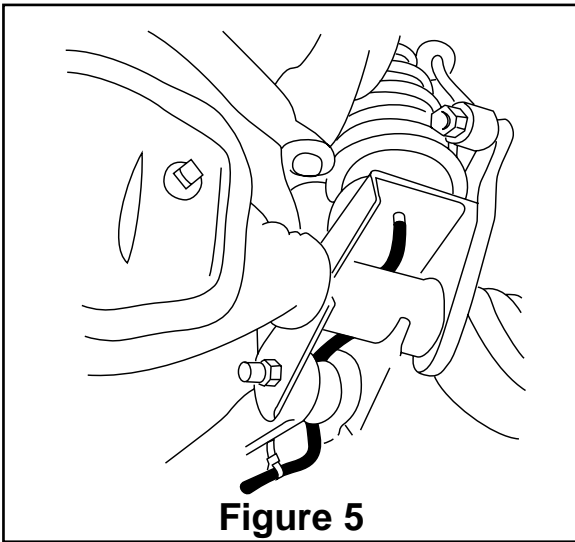
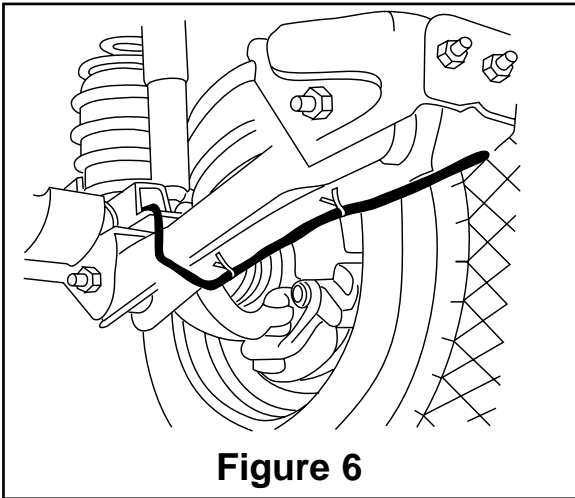


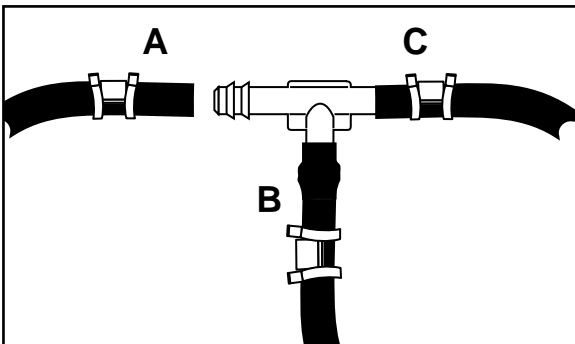
1. Raise vehicle and place jack stands under frame.
2. Remove the wheel and tire assemblies.
3. Remove lower shock absorber attaching bolts (Figure 1, item 1).
4. Remove lower springs retaining strap and bolts (Figure 1, item 2).
5. Remove stabilizer bar upper link retaining nuts, washers and bushings (Figure 2, item 1).
6. It will be necessary to remove the bolt on one end of the lower control arm to remove the coil spring. On some models there is an adjustable cam for suspension adjustment. Remove the opposite (non-adjustable) end bolt. If you find it necessary to remove the adjustable end bolt, the front suspension will have to be aligned.
7. Remove track bar attaching bolt (Figure 2, item 2).
8. Carefully lower axle and observe the brake lines being cautious not to strain them.
9. Using a pair of channel lock pliers, reach in through the turns of the coil to unscrew and remove the rubber jounce bumper (Figure 2, item 3).
10. Mark the index location of the coil spring end on the lower seat. Remove coil spring by lifting off the seat and pulling out toward rear of vehicle.
11. Drill 3/4" hole in center of lower spring seat using indentation as a guide. CAUTION - The hole must be no less than 3/4" and centered to properly nest the air cylinder valve base and prevent wear damage (Figure 3).
12. Mount the protector in place of the jounce bumper using the hex head bolt (Figure 4).
13. Insert air cylinder into coil spring with stem located at the bottom.
14. Install coil spring and air cylinder assembly. Be sure to nest inflation valve base in drilled hole in the spring seat.
15. Install Air Line kit. User may select either Dual Air Line or Tee Air Line option depending on use of vehicle. Dual Air Line installation is recommended to allow side-to-side leveling for uneven load (see Air Line installation instructions before continuing).



**Figure 5**

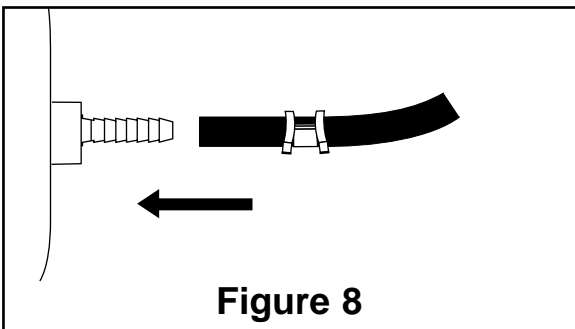


**Figure 6**



Use this procedure for all air line connections:  
**A.** Slide air line clamp onto the air line  
**B.** Push the air line over the barbed stem.  
**C.** Compress the ears on the air line clamp with pliers and slide it forward to fully cover the barbed section.

**Figure 7**



**Figure 8**

16. Carefully raise axle.
17. Replace lower spring retaining strap and bolts.
18. Replace stabilizer bar upper link retaining nuts, washers and bushings (torque 14 ft. lbs.).
19. Replace lower shock absorber attaching bolts (torque 25 ft. lbs.).
20. Replace track bar attaching bolt (torque 55 ft. lbs.).
21. Replace forward lower control arm attaching bolts (torque 133 ft. lbs.).
22. Repeat on other side of vehicle.
23. Inflate Air Springs to 50 p.s.i. Check for air leaks at all fittings and valve core with soapy/water solution and making any necessary repairs.
24. Replace wheels, remove safety stands and carefully lower vehicle to ground.
25. Deflate Air Springs in 10 p.s.i. intervals to determine best ride and handling. A minimum of 10 p.s.i. air pressure must be maintained to help prevent bottoming-out on large bumps, chuckholes, etc, and to prevent premature cylinder failure.
26. Read Maintenance/Operation Tips for proper care of your air Cylinders (see page 4).

Tee air line installation recommended unless weight in vehicle varies from one side to the other and unequal pressures are needed to level the load. Dual air lines are used in this case.

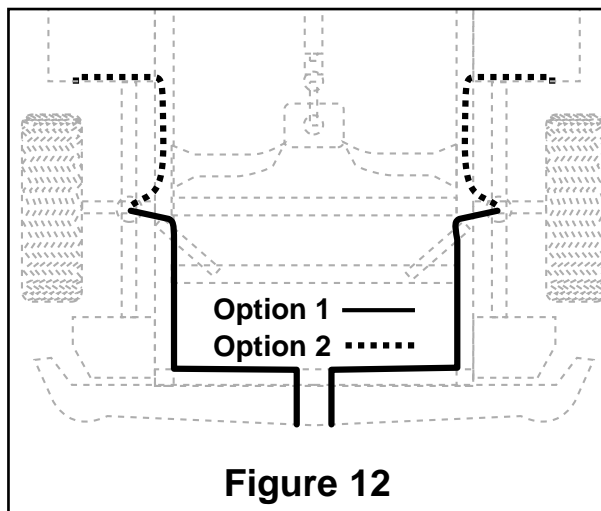
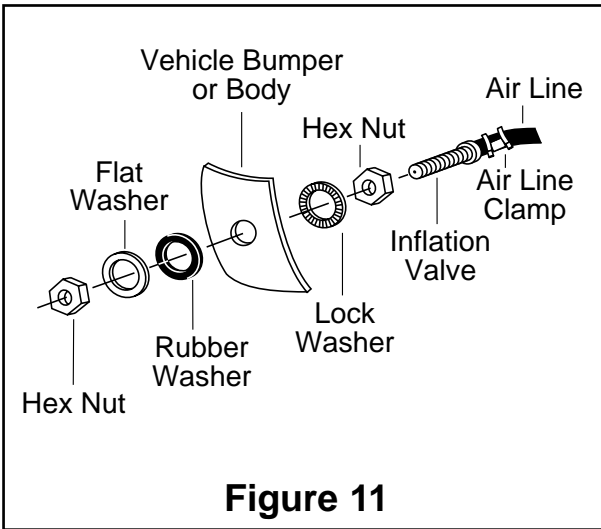
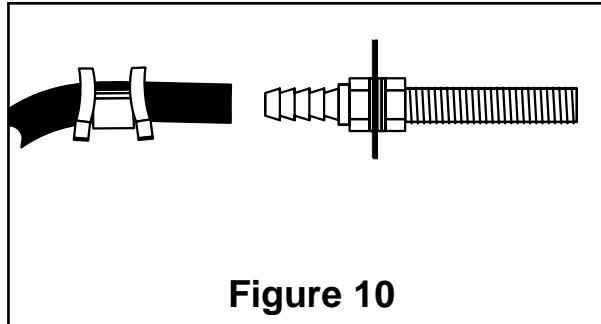
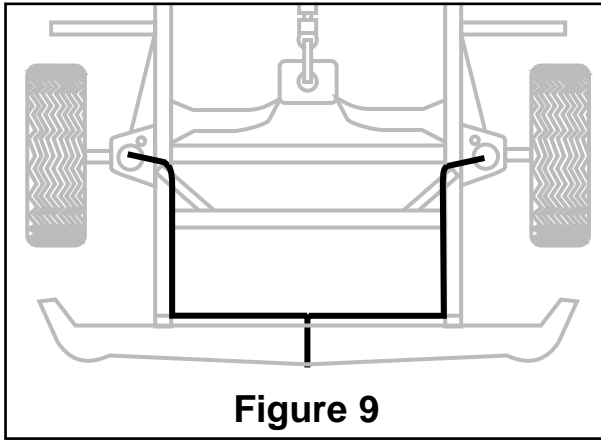
#### TEE AIR LINE ROUTING

**TO PREVENT AIR LINE FROM MELTING, KEEP IT AT LEAST EIGHT INCHES FROM EXHAUST SYSTEM.**

- A. Locate desired tee location on the frame rail or cross member.
- B. Determine and cut adequate length of air line to reach from tee to left and right side on air cylinders.

**CAUTION: LEAVE SUFFICIENT AIR LINE SLACK TO PREVENT ANY STRAIN ON FITTING DURING AXLE MOTIONS.**

- C. Slide air line clamp onto the air line.
- D. Push the air line over one side of the tee until all the barbs are covered. Repeat procedure for other leg of tee (Figure 7). With pliers slide the air line clamp forward until it fully covers the barbed section. Repeat for other leg of tee.
- E. Route along cross member and either lower control arm or upper spring seat to air cylinder.
- F. Insert air line through spring seat and slide on air line clamp.



- G. Push the air line onto the stem, covering all the barbs. With pliers slide the air line clamp upward until it fully covers the barbed section.
- H. Push the remaining air line over the last fitting on tee and route along frame to desired inflation valve location (Figure 9). Attach with plastic straps or wire.
- I. Select a location for inflation valve in the hood release, front bumper, fender flange or behind the license plate, assuring that the valve will be protected and accessible with an air hose.
- J. Drill a 5/16" hole for inflation valve and mount as in illustration (Figure 11). Rubber washer is for outside weather seal.
- K. Slide air line clamp over the air line. Push air line onto fitting covering all barbs, with pliers slide the air line clamp forward until it fully covers the barbed section (Figure 10).
- L. Raise axle or lower body until air cylinders lightly touch upper spacer and lower spring seat.

**DO NOT INFLATE AIR CYLINDERS BEFORE READING MAINTENANCE & OPERATING TIPS.**

M. Continue with step 16, page 1.

**DUAL AIR LINE ROUTING**

**TO PREVENT AIR LINE FROM MELTING, KEEP IT AT LEAST EIGHT INCHES FROM EXHAUST SYSTEM.**

- A. Select a location for inflation valve in the hood release, front bumper, fender flange or behind the license plate, assuring that the valve will be protected and accessible with an air hose.
- B. Determine and cut adequate length of air line to reach from valve location to left side air cylinder.

**CAUTION: LEAVE SUFFICIENT AIR LINE SLACK TO PREVENT ANY STRAIN ON VALVE STEM DURING NORMAL AXLE MOTIONS.**

- C. Insert the air line through the lower spring seat.
- D. Slide air line clamp onto the cut air line.
- E. Push the air line onto the stem, covering all the barbed section (Figure 8). With pliers slide the air line clamp forward until it fully covers barbed section.
- F. Repeat process for right side.
- G. Drill 5/16" hole for inflating valves and mount as illustrated. Rubber washer is for outside weather seal (Figure 11).
- H. Route air line along control arm and frame to inflation valve location and cut off excess.

- I. Slide air line clamp onto the air line and push the air line over the fitting, covering all the barbs. With pliers slide the air line clamp forward until it fully covers the barbed section (Figure 10).
- J. Raise axle or lower body until air cylinders lightly touch upper spacer and lower spring seat.
- K. Attach shock absorbers if removed earlier in the installation.

**DO NOT INFLATE AIR CYLINDERS BEFORE READING MAINTENANCE & OPERATING TIPS.**

- L. Continue with step 16, page 1.

**FAILURE TO MAINTAIN MINIMUM PRESSURE WILL VOID THE WARRANTY**

<b>MINIMUM AIR PRESSURE 10 P.S.I.</b>	<b>MAXIMUM AIR PRESSURE 50 P.S.I.</b>
<p><b>MAINTENANCE TIPS:</b></p> <ol style="list-style-type: none"> <li>1. Check pressure weekly!</li> <li>2. Always maintain at least 10 p.s.i. air pressure to prevent chafing or coil pinch.</li> <li>3. If you develop an air leak in the system, use a soapy/water solution to check all air line connections and the valve core before removing cylinder.</li> </ol> <p><b>OPERATING TIPS:</b></p> <ol style="list-style-type: none"> <li>1. Inflate your air springs to 50 p.s.i. before adding the payload. This will allow the air cylinder to properly mesh with the coil spring. After vehicle is loaded, adjust your air pressure (down) to level the vehicle and for ride comfort.</li> <li>2. When you are carrying a payload it will be helpful to increase the tire inflation pressure in proportion to any overload condition. We recommend a 2 p.s.i. increase above normal (not to exceed tire manufacturers maximum) for each 100 lbs. additional load on the axle.</li> </ol>	
 <p><i>Thank you for purchasing Air Lift Products</i></p> <p><b>AIR LIFT COMPANY</b>  <b>P.O. BOX 80167</b>  <b>Lansing, MI 48908-0167</b></p>	
<b>FOR TECHNICAL ASSISTANCE CALL 1-800-248-0892</b>	
<b>Caution: DO NOT EXCEED THE VEHICLE MANUFACTURERS MAXIMUM GROSS VEHICLE WEIGHT RATING.</b>	



# Product Use Information

## Frequently asked questions

**Q. Will installing air springs increase the weight ratings of a vehicle?**

No. Adding air springs will not change the weight ratings (GAWR, GCWR and/or GVWR) of a vehicle. Exceeding the GVWR is dangerous and voids the Air Lift warranty.

**Q. Is it necessary to keep air in the air springs at all time and how much pressure will they need?**

The minimum air pressure should be maintained at all times. The minimum air pressure keeps the air spring in shape, ensuring that it will move throughout its travel without rubbing or wearing on itself.

**Q. Is it necessary to add a compressor system to the air springs?**

No. Air pressure can be adjusted with any type of compressor as long as it can produce sufficient pressure to service the springs. Even a bicycle tire pump can be used, but it's a lot of work.

**Q. How long should air springs last?**

If the air springs are properly installed and maintained they can last indefinitely.

**Q. Will raising the vehicle on a hoist for service work damage the air springs?**

No. The vehicle can be lifted on a hoist for short-term service work such as tire rotation or oil changes. However, if the vehicle will be on the hoist for a prolonged period of time, support the axle with jack stands in order to take the tension off of the air springs.

## Tuning the air pressure

Pressure determination comes down to three things — level vehicle, ride comfort, and stability.

**1. Level vehicle**

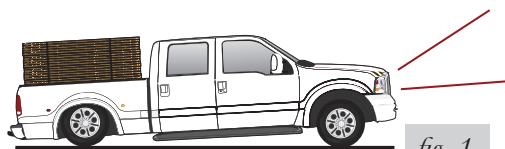
If the vehicle's headlights are shining into the trees or the vehicle is leaning to one side, then it is not level (fig. 1). Raise the air pressure to correct either of these problems and level the vehicle.

**2. Ride comfort**

If the vehicle has a rough and harsh ride it may be due to either too much pressure or not enough (fig. 2). Try different pressures to determine the best ride comfort.

**3. Stability**

Stability translates into safety and should be the priority, meaning the driver may need to sacrifice a perfectly level and comfortable ride. Stability issues include roll control, bounce, dive during braking and sponginess (fig. 3). Tuning out these problems usually requires an increase in pressure.



Bad headlight aim



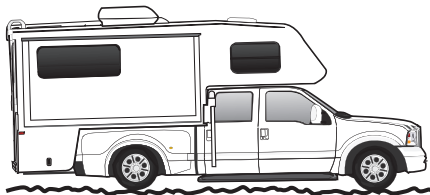
Sway and body roll



Rough ride

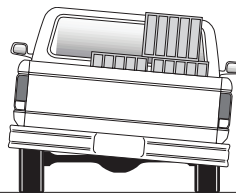
**Guidelines for adding air:**

1. Start with the vehicle level or slightly above.
2. When in doubt, always add air.
3. For motorhomes, start with 50-100 PSI in the rear because it can be safely assumed that it is heavily loaded.
4. If the front of the vehicle dives while braking, increase the pressure in the front air bags, if equipped.
5. If it is ever suspected that the air bags have bottomed out, increase the pressure (fig. 4).
6. Adjust the pressure up and down to find the best ride.
7. If the vehicle rocks and rolls, adjust the air pressure to reduce movement.
8. It may be necessary to maintain different pressures on each side of the vehicle. Loads such as water, fuel, and appliances will cause the vehicle to be heavier on one side (fig. 5). As much as a 50 PSI difference is not uncommon.

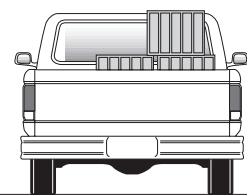


Bottoming out

fig. 4



Unlevel



Level

fig. 5

## Warranty and Returns Policy

Air Lift Company warrants its products, for the time periods listed below, to the original retail purchaser against manufacturing defects when used on catalog-listed applications on cars, vans, light trucks and motorhomes under normal operating conditions for as long as Air Lift manufactures the product. The warranty does not apply to products that have been improperly applied, improperly installed, used in racing or off-road applications, used for commercial purposes, or which have not been maintained in accordance with installation instructions furnished with all products. The consumer will be responsible for removing (labor charges) the defective product from the vehicle and returning it, transportation costs prepaid, to the dealer from which it was purchased or to Air Lift Company for verification.

Air Lift will repair or replace, at its option, defective products or components. A minimum \$10.00 shipping and handling charge will apply to all warranty claims. Before returning any defective product, you must call Air Lift at (800) 248-0892 in the U.S. and Canada (elsewhere, (517) 322-2144) for a Returned Materials Authorization (RMA) number. Returns to Air Lift can be sent to: Air Lift Company • 2727 Snow Road • Lansing, MI • 48917.

Product failures resulting from abnormal use or misuse are excluded from this warranty. The loss of use of the product, loss of time, inconvenience, commercial loss or consequential damages is not covered. The consumer is responsible for installation/reinstallation (labor charges) of the product. Air Lift Company reserves the right to change the design of any product without assuming any obligation to modify any product previously manufactured.

This warranty gives you specific legal rights and you may also have other rights that vary from state-to-state. Some states do not allow limitations on how long an implied warranty lasts or allow the exclusion or limitation of incidental or consequential damages. The above limitation or exclusion may not apply to you. There are no warranties, expressed or implied including any implied warranties of merchantability and fitness, which extend beyond this warranty period. There are no warranties that extend beyond the description on the face hereof. Seller disclaims the implied warranty of merchantability. (Dated proof of purchase required.)

**Air Lift 1000 ..... Lifetime Limited**  
**RideControl ..... Lifetime Limited**  
**SlamAir ..... Lifetime Limited**  
**LoadLifter 5000\* ..... Lifetime Limited**  
**EasyStreet Systems ..... 1 Year Limited**

**Load Controller (I) ..... 2 Year Limited**  
**Load Controller (II) ..... 2 Year Limited**  
**SmartAir ..... 2 Year Limited**  
**Wireless AIR..... 2 Year Limited**  
**Other Accessories..... 2 Year Limited**

*\*formerly SuperDuty*